



Natural elegance

OSRAM DULUX® TABLE SPRING

SEE THE WORLD IN A NEW LIGHT

OSRAM



Bright and beautifully

There are table lights that catch the eye because of their quality of light. There are others that stand out because of their attractive design. And there are some that attract attention because they are inexpensive to buy or to run. But only very few combine all these benefits so perfectly as the OSRAM DULUX® TABLE SPRING.

Decorative and functional

This new table lamp oozes elegance. The transparent blue inset in the luminaire head and the blue adjustment knobs provide an attractive contrast to the aluminium of the rest of the table light. Another highlight is the degree to which the light can be directed. The head can be swivelled and the arm can be rotated for maximum flexibility.

OSRAM DULUX® TABLE SPRING is available as a single-arm version with a clamp and as a two-arm version with a clamp or base. All of which makes this light ideal for the home or office.



An economical all-rounder

OSRAM DULUX® TABLE SPRING is pleasing not only on the eye. It is kind to the pocket and will look great anywhere. The control gear is integrated in the plug and the light comes complete with an OSRAM DULUX® S 11 W compact fluorescent lamp. Compared with an ordinary 75 W light bulb it will save around 80% in electricity costs.

OSRAM DULUX® TABLE SPRING can be placed anywhere. There is no need for assembly. It is ready to use, complete with 2 m mains cable, plug and a switch mounted on the head. Available in silver/blue.



OSRAM DULUX® TABLE SPRING looks good on any work surface or desk.



Technical data

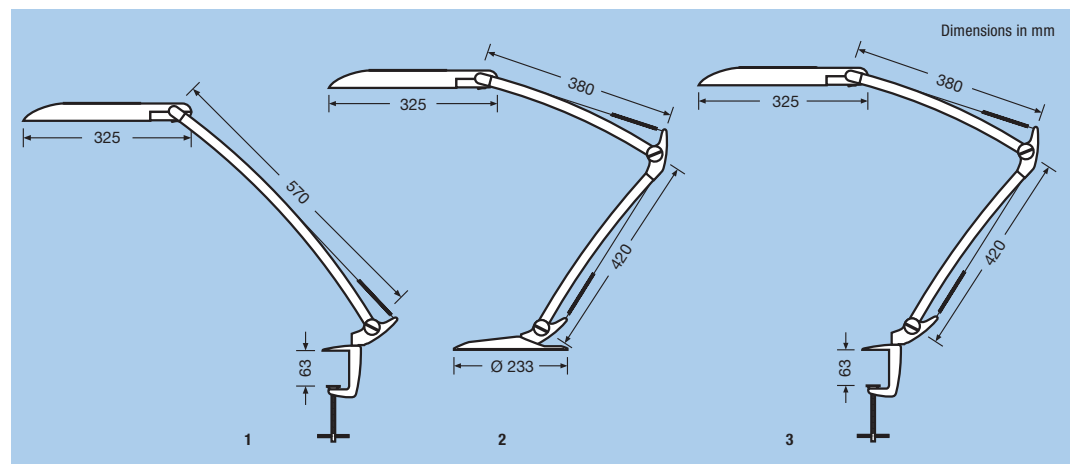

OSRAM DULUX®	TABLE SPRING 1 with clamp	TABLE SPRING 2 with base	TABLE SPRING 2 with clamp
Order no.	73158	73159	73160
EAN code	4050300667270	4050300667232	4050300667256
Colour	silver/blue	silver/blue	silver/blue
Weight	1040 g	3750 g	1170 g
Supply voltage	230 V	230 V	230 V
Mains frequency	50 Hz	50 Hz	50 Hz
Equipped with lamp	OSRAM DULUX-S11W/830	OSRAM DULUX-S11W/830	OSRAM DULUX-S11W/830
Protection class	II	II	II
Type of protection	IP20	IP20	IP20
Approval marks			
Standard pack	4	4	4
Fig. no.	1	2	3

member of
voltimum
.com